

INTERIOR PRODUCT SOLUTIONS

CORNER GUARD

HS-605B

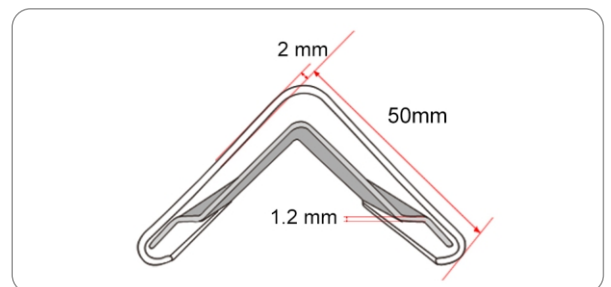

Specifications and Materials:

- Vinyl and profiles are GREENGUARD certified, ABS end Caps
- 1.96" (50mm) Width
- 080" (2mm) vinyl cover
- 90 Degree Edge, 1.2/1.6/1.8mm Aluminum
- Color: Plain color or stripe color , Any color or wood color can be customized
- Full screws match with Corner Guard

Specifications and Materials:

- Markets: Middle east, southeast Asia, Europe about 80 countries
- Inspection progress: Pre- production meeting, in line, end of line
- Inspection rate:30% of order quantity
- Produce Ability: 30000m /week
- Injection line: 15
- Extruding line:10
- Worker:200
- Factory scale:9000 SQM
- QTY of Products items : more than 100

Features:

- Fire retardant
- Anti -bacterial
- ASTM G 21-15 Standard Practice
- 5 Years product warranty
- Easy to clean
- Environmental protect on material
- Cost-effective
- Strong and crash system
- Certifications: CE/ISO9001/SGS/TUV/BV

PRODUCT INSTALLATION

FIG.1

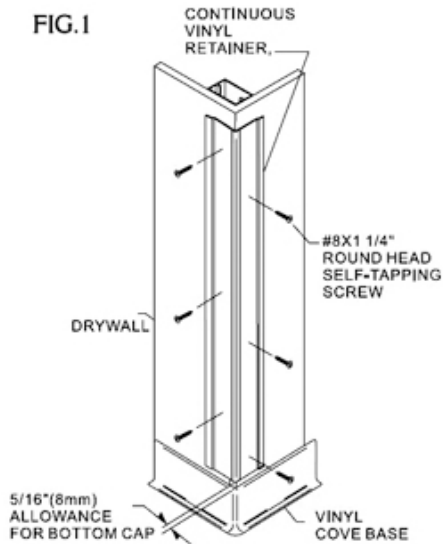

Please read all instructions before installing corner guards. Material must be stored, installed and used in environmentally controlled conditions.

1. Position vinyl retainer against wall, leaving allowance for bottom cap, secure retainer to the wall by staggering fasteners on each wing of the retainer, see Figure 1.

FIG.2

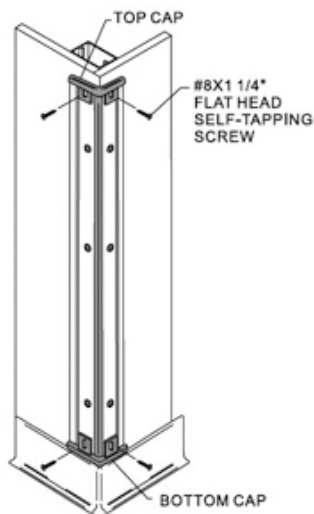

2. Overlap the retainer with the mounting tabs of the top and bottom caps and attach them to retainer. Stagger the fasteners on each wing of the cap. See Figure 2. When installing flexible top caps on custom angle corner guards, use cup washers and flat head screws to fasten the top caps to the retainer, See Figure 2a.

FIG.2



FIG.3

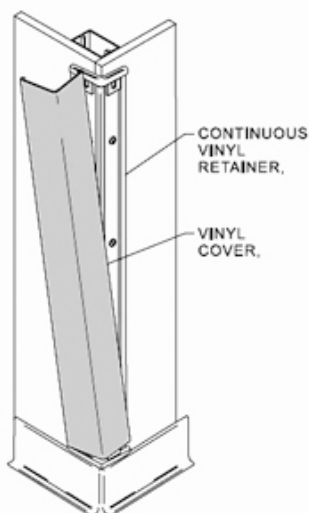

3. Position cover on retainer and adjust the top cap for a tight fit. Starting at the top, push cover onto retainer pressing over the entire length until it snaps into place. See Figure 3.